

UNIPOINT V2

C R H Electronics Design

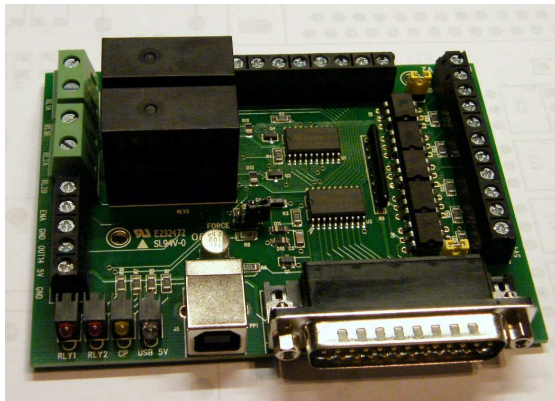

Uniport V2

**USB powered Parallel port interconnection board
with optical isolated inputs, buffered outputs,
charge pump interlock and power relays**

By C R Harding

Specification

- Full optical isolation of all inputs.
- Four XYZA Axis buffered outputs to stepper control boards.
- Integrated Charge pump logic line protects all outputs.
- High current (30mA max) stepper drive outputs with charge pump interlock.
- LED status indicators for Power, CP, Relays 1&2.
- USB type B computer power socket
- Charge pump override jumper
- Mainly surface mount components for greater reliability.
- Board size 107 X 80 mm. FR4, Immersion gold, 1oz copper, RoHS compliant.
- Two 16A, 240V AC control relays with single pole contacts.
- Input power jumpers for different configurations.
- Alternative 5 volt input power connection.
- Only consumes 150mA with all relays activated.

Manual V2.0 March 09

Hardware V2.0 March 09

Introduction

As quite a few stepper driver boards now have built in optical isolation but need a reasonable amount of drive current, a product was needed to interface with these driver boards. The Uniport board addresses this problem by providing high current drive for all stepper signals with charge pump control for maximum protection and high frequency performance for very fine step

rates. Four axis, step and direction signals are available and five inputs to the board which are optically isolated with optional power jumpers provided to configure as desired. To simplify power requirements the whole board can be powered from a standard computer USB port or an external regulated 5 volt DC connection if available. For power switching motors, pumps etc the Uniport board is equipped with two 16 Amp power relays that also have charge pump interlock protection.

Description

The Uniport board is an optical isolated input parallel breakout board with the addition of a charge pump, power save circuits and relay control outputs. All stepper drive outputs are buffered with up to 30mA of drive current and a high frequency operation making them ideal to drive optically isolated stepper boards. Unlike the basic parallel brake-out boards the Uniport board has designated X, Y, Z & A motor control step and direction pins that will need to be matched in the user software. All these step and direction signals are actually treated the same way in hardware and can be made interchangeable if there is no software option. The chart fig1 gives the pin-out reference used in the design. The Charge pump circuit uses the 12 KHz signal configured to pin one of the parallel port generated by the CNC software when the program is up and running correctly. The logic level obtained from this signal controls either an enable or sleep pin on the stepper motor drive board or boards. There is a charge pump override jumper J13. This can be used for test purposes or connected permanently if your software does not support a charge pump signal. The charge pump signal is gated into the buffer chips so that they are disabled without this signal present. This means that driver boards that have no enable signal pins are still made safe by having their input signals removed. This charge pump signal is also gated into all relay outputs so no false triggering of the relays can occur while the software is not running.

The Uniport board has five signal inputs each with its own series limiting resistor. The resistor value is set to give 5mA current through the device on a 5V supply. The input ports 1-3 have their limiting resistors connected to the external 5 volt pin which can be linked across to the internal 5V line with jumper L3. Jumper L2 also links the boards ground to the 0V terminals.

With both links in position you can wire switches between input and ground with no external component. This of course bypasses the full isolation afforded by the opto-isolators. Inputs 4 & 5 are totally independent and need an external 5V signal to operate them unless you link wires from the other terminals. Fig 2 shows how the inputs are arranged. If you wish to use a 12V signal on these inputs then an additional resistor of 1.8K ohms in series with the input will be required.

Notes : The control software must have the charge pump signal set to pin1 and be present for the board to be enabled unless the override link is on.

Fig1

Parallel Port Pin	Uniport Output	Input/Output
1	Charge pump signal	Out
2	X Direction	Out
3	X Step	Out
4	Y Direction	Out
5	Y Step	Out
6	Z Direction	Out
7	Z Step	Out
8	A Direction (4th Axis)	Out
9	A Step (4th Axis)	Out
10	Input 1	(isolated) In
11	Input 2	(isolated) In
12	Input 3	(isolated) In
13	Input 4	(isolated) In
15	Input 5	(isolated) In
14	Output	Out (SP)
16	Relay1	Out (SP)
17	Relay2	Out (SP)
18-25 computer ground	Ground reference	

Connections

You will need two cables from your computer to the Uniport board. A standard parallel port 25 way male to female lead provides all the signal information. A standard USB A to B lead provides a 5 volt power supply for the Uniport board. Alternatively there is a 5 volt power connection available. This voltage must be a regulated 5V DC supply.

A system wiring setup to a DRV25DUAL board is shown in Fig 3.

Fig4 shows a simple limit switch serial circuit and emergency stop switch using two inputs to the Uniport board. All micro switches are normally closed connection. Configure controlling software to stop on change of input signal pin parallel port (11) and limit switches on pin (10). Other inputs could be used for home switches or separate banks of limit switches for each axis.

The software manual usually describes these functions in more detail. Fig5 shows connecting relay output one to controlling spindle motor and relay two a coolant pump. The pump or motor is simply connected to the normally open connection RLYA and power applied to the RLYB common. Activating the relay closes the contacts completing the circuit. Utmost care should be taken handling the Uniport board when there are live mains connections connected to the PCB as the relay terminals are exposed on the underside of the board. It is better to bolt the board down to the case or a side panel with a small gap to stop fingers being inserted underneath.

Fig 2 Opto isolator input connections

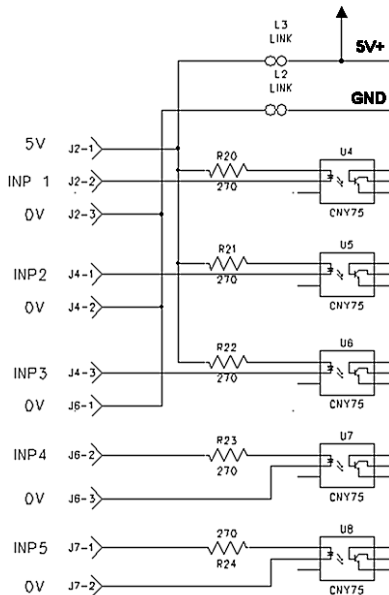
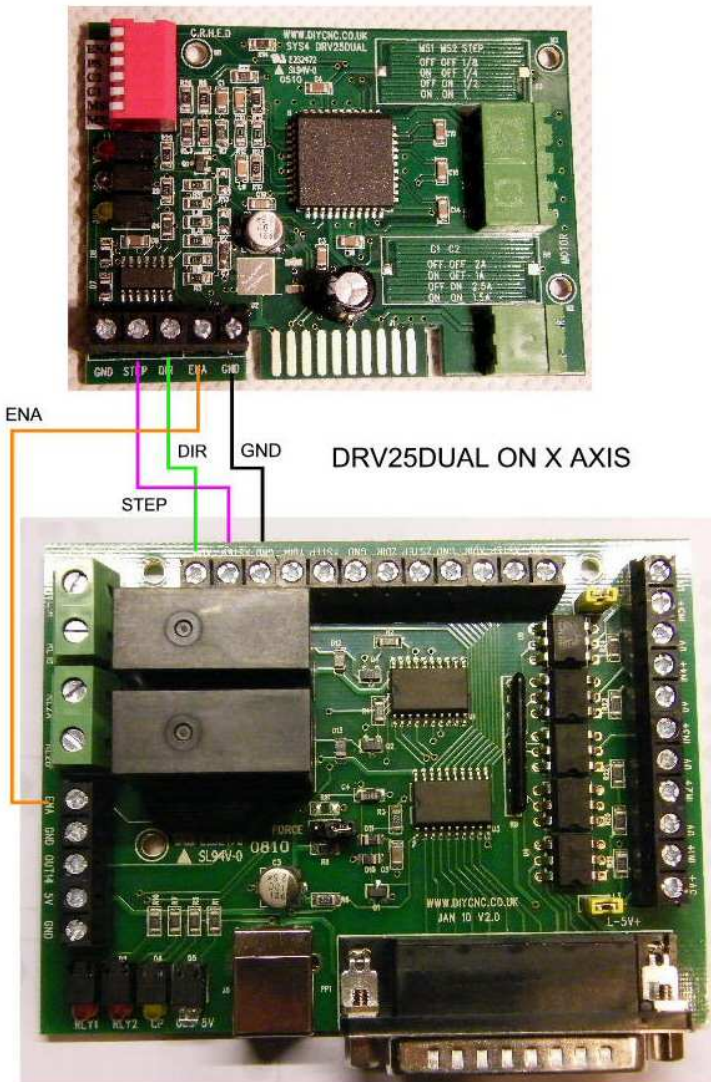
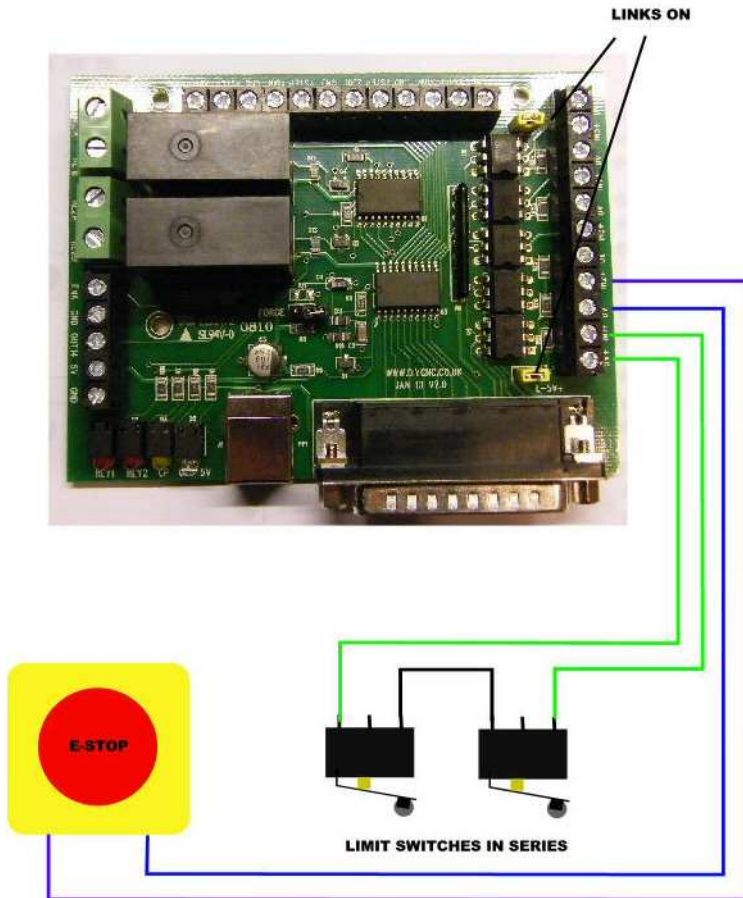

Fig3 Connecting DRV25DUAL to UNIPORT



**Repeat as required for further Axis. Only one 5volt lead needs to be connected enable and PS will need to be common between boards.
Fig4 Input wiring.**



With links in position, inputs four and five are still fully isolated from power and ground.

Fig5 Relay connections

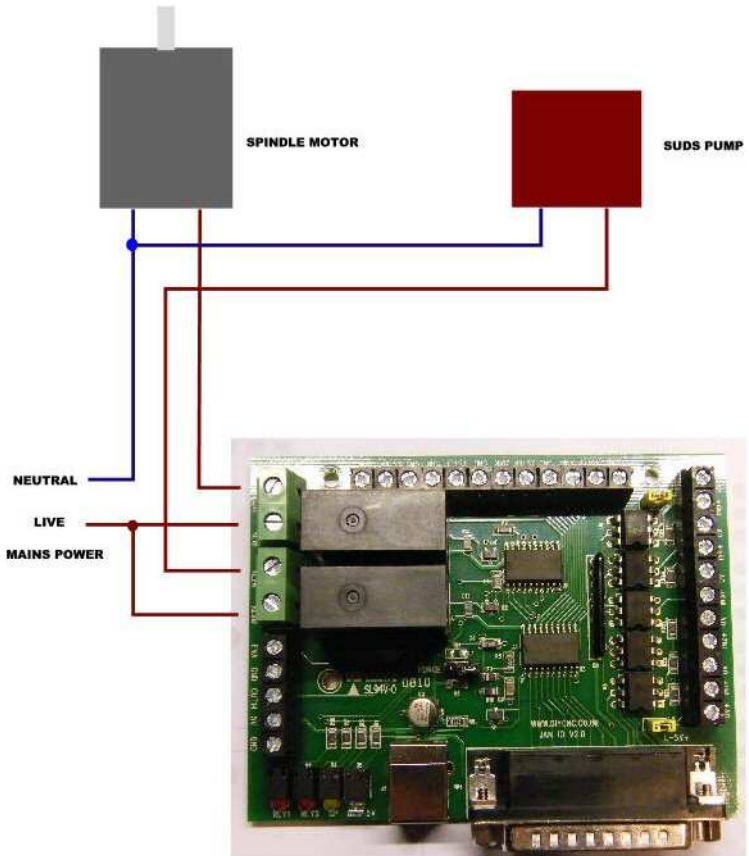

Contact Details

J Harding
5 Colwyn Drive
Knypersley
Stoke-on-Trent
Staffs
ST8-7BJ

roy@diycnc.co.uk
www.diycnc.co.uk

Dimensions

